



MECTROL®

POSICLEAN® FOOD GRADE BELTING



Gates Mectrol PosiClean is a positive drive belt designed to be an easy to clean replacement of plastic modular chain in the food processing industry.

PosiClean belting has Kevlar® tension members sealed inside a urethane base belt to limit stretch and create a smooth surface to facilitate cleaning to a microbiological level.

FEATURES

- > Clean-in-place process
- > Urethane material compatible with wash down environments
- > Kevlar® tension members provide high strength, low stretch
- > Sealed edges and tension members prevent ingress of microbes
- > Can be welded endless or spliced with stainless steel or PosiLace™ pin system
- > USDA accepted for meat, poultry and dairy processing equipment

BENEFITS

- > Reduction of in-process bacteria growth
- > Cut water usage and costs by 45%
- > Longer belt life due to minimal belt stretch
- > Reduce cleaning time by 50%

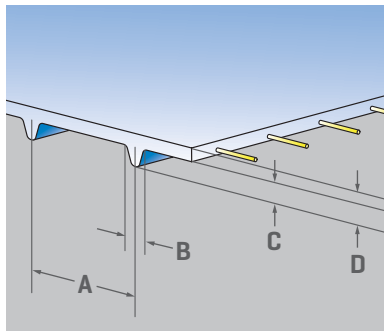

	PC20	PC10
A - Distance Between Teeth	2.000"	1.000"
B - Tooth Width	0.301"	0.169"
C - Tooth Height	0.226"	0.138"
D - Belt Thickness with Tooth	0.354"	0.236"

PC20

- > Available in two cord per inch for light to medium applications and four cord per inch for high torque applications
- > Direct drop-in replacement for most 2" plastic modular belt
 - 180° wrap around most 8, 10, and 12 tooth modular pulleys
- > 4" minimum pulley diameter
- > Can be used with the PosiLace™ pin fastening system

PC10

- > Smaller diameter, 2" minimum, pulley is typically used for better handoffs
- > Direct drop-in replacement for most 1" plastic modular belting

POSICLEAN® FOOD GRADE BELTING

POSICLEAN <> SPECIFICATIONS

BELT OPTIONS	PC20			PC10
	Standard	Hi Torque	Cold Temp	Standard
Designator	KV-FDA	HDK-FDA	HDK-R6	KV-FDA
Cords/Inch	2	4	4	2
Pitch (nominal)	2"	2"	2"	1"
Specific Belt Weight [lbs/ft/in]	0.078	0.078	0.078	0.059
Specific Belt Stiffness [lbs/inch/inch]	7400	11800	11800	7400
Min. Sprocket Dia.	3.76"	3.76"	3.76"	2.00"
Min. Back Bend Dia.	6"	6"	6"	3.5"
Service Temperature Range	-4° to 158° F	-4° to 158° F	-10° to 158° F	+8° to 160° F
Coefficient of Friction				
Urethane vs. UHMW (dry)	0.53 to 0.69	0.53 to 0.69	0.54 to 0.69	0.30 - 0.40
Urethane vs. Stainless Steel (dry)	0.74 to 0.94	0.74 to 0.94	0.64 to 0.68	0.50 - 0.60
Color	Blue	Blue	Blue	Blue
Min. and Max. Width	8"/36"	8"/36"	8"/36"	6"/36"

FASTENING OPTIONS

Max. Allowable Tension [lbs per inch width]⁽¹⁾

Factory Weld (Finger Length PC20 - 3.35", PC10 - 3.02")	30	51	50	30
Field Weld (Finger Length 25 mm)	22	39	35	N/A
Field Weld Straight Cut	15	26	24	19
PosiLace™	13	13	13	N/A
Flexco® UX1SS Clipper® Wire Hooks	15	26	23	15
Flexco® APF150 Alligator® Plastic Rivet	15	26	23	N/A
Flexco® APF100 Alligator® Plastic Rivet	N/A	N/A	N/A	15
Flexco® RS125 Alligator® Ready Set™ Staple	15	26	23	N/A
Flexco® RS62 Alligator® Ready Set™ Staple	N/A	N/A	N/A	15

(1) Max allowable is set at the lower of 25% yield strength or 2% stretch at weld or splice



1" Pitch Sprocket



2" Pitch Sprocket

FOOD GRADE BELT <> SLIT WIDTH TOLERANCE

Up To and Including 4"	>4" to 12"	>12" to 16"	>16" to 20"	>20" to 24"	>24" to 28"	>28" to 32"	>32"
+0/- .100"	+0/- .120"	+0/- .125"	+0/- .160"	+0/- .190"	+0/- .225"	+0/- .240"	+0/- .255"

POSICLEAN SPROCKET™ <> SPECIFICATIONS

Number of Teeth		PC20				PC10				
		6	8	10	12	6	8	10	12	20
Nom. Outside Diameter	inch	3.7	4.9	6.2	7.5	1.9	2.5	3.2	3.8	6.4
	mm	94	126	158	189	48	64	81	97	163
Nominal Width	inch	1.3	1.3	1.3	1.3	1	1	1	1	1
	mm	32	32	32	32	25.4	25.4	25.4	25.4	25.4
Bore Sizes	Square, in	1.5	1.5	1.5	1.5	N/A	N/A	1.5	1.5	1.5
	Round*, in	1	1	N/A	N/A	1	1	1	N/A	N/A
	Square, mm	40	40	40	40	N/A	N/A	40	40	40
	Round*, mm	30	30	N/A	N/A	N/A	N/A	25	N/A	N/A
Material		UHMW-PE				UHMW-PE				

* Imperial keyway sizes on round bores conform to ANSI standard B17.1 - 1967 (R1989); metric keyway sizes conform to BS 4235: Part 1: 1972 (1986)

GATES MECTROL, INC.

9 Northwestern Drive
Salem, NH 03079
Tel. +1 (603) 890-1515
Tel. +1 (800) 394-4844
Fax +1 (603) 890-1616
Email: contact@gatesmectrol.com
GatesMectrol.com

Kevlar® is a registered trademark of E.I. du Pont de Nemours and Company.

Flexco®, Clipper®, and Alligator® are registered trademarks of Flexible Steel Lacing Company.

© Copyright 2012 Gates Mectrol Incorporated. All rights reserved.

GM PosiClean 6-2012

POSICLEAN SPROCKET + SUPPORT GUIDELINES <> PC10 AND PC20

Belt Width	inch	6	9	12	15	18	21	24	27	30	36
Min. No. Sprockets [Max. 5" spacing center to center]		3	3	4	4	5	6	6	7	7	9
No. of Sprockets for Max. Allow. Tension [Max. 3" spacing center to center]		3	4	5	6	7	8	9	10	11	13
Min. No. Carryway Supports [6" spacing center to center]		2	3	3	4	4	5	5	6	6	7